

# American Safe Room

## Explosion Resistant

### Blast Hatch

#### with

### Integrated Riser

Deadbolt lock

Closing handle

Optional escape jack mount

Lift strut

EPDM compression seal

Optional viewers

Mounting slots  
for easier positioning  
than mounting holes



Pre-production riser hatch  
without cam latch

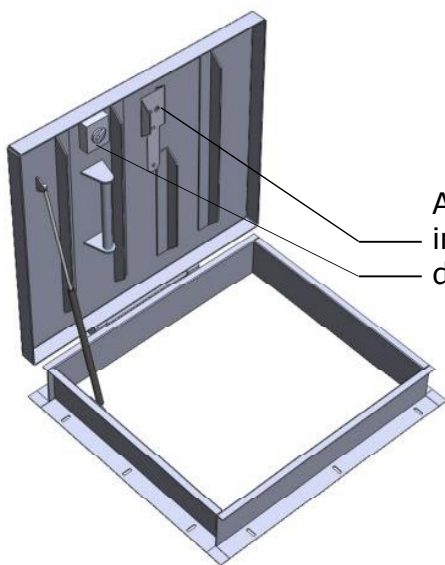

All hatches now ship with  
internal cam latch and  
deadbolt lock

Emergency escape hatch  
32 x 32 x 6 inch height

**Drawing: ASR-50-RBH**  
**Revision: H**  
**May 17, 2012**

## Table of Contents

Description .....	3
Options .....	4
Order form .....	5
Option: left or right hand hatch .....	6
Option: viewers .....	7
Option: emergency escape jack .....	8
Option: external ladder extension .....	9
Option: internal ladder assembly .....	10
Calculating the height of the first rung from the floor .....	10
Dimensional constraints .....	11
Installation .....	12
Mounting the riser on an American Safe Room shelter .....	13
Mounting the riser on a conventional concrete shelter .....	14
Installing the internal ladder assembly .....	15
Installing the concrete wedge anchors .....	16

**COPYRIGHT ©2011 LEONARD M. HENRIKSON, ALL RIGHTS RESERVED  
THE DRAWINGS AND TEXT IN THIS MANUAL ARE COPYRIGHTED MATERIAL**

## Description

The ASR-50-RBH Riser Blast Hatch is designed to be installed on an underground shelter. It features an integrated riser that can be ordered in custom heights to match the backfill depth of the shelter.

It is supplied with a coat of shop primer and includes concrete wedge anchors for mounting it on the roof of a concrete shelter.

The blast lid is constructed from ASTM A-36 steel plate laterally reinforced by 4 stress resistant steel bars. It is designed to withstand 40 PSI blast load. It uses a gas lift cylinder to assist the opening. The riser tunnel is also constructed from ASTM A-36 steel plate with strategically placed reinforcement stiffeners.

The hinge assembly is the same massive one used on our ASR-50-BD Blast Doors. It features bronze bushings, grease zerks, and an inch and half 1018 alloy steel pin.

The inner cam latch is the same one we use on our blast doors. It compresses the EPDM seal on the lip and sucks the rain hood down over the riser.

The external heavy duty dead bolt cylinder style key lock has a steel external weather guard constructed from ASTM A53 grade A steel.

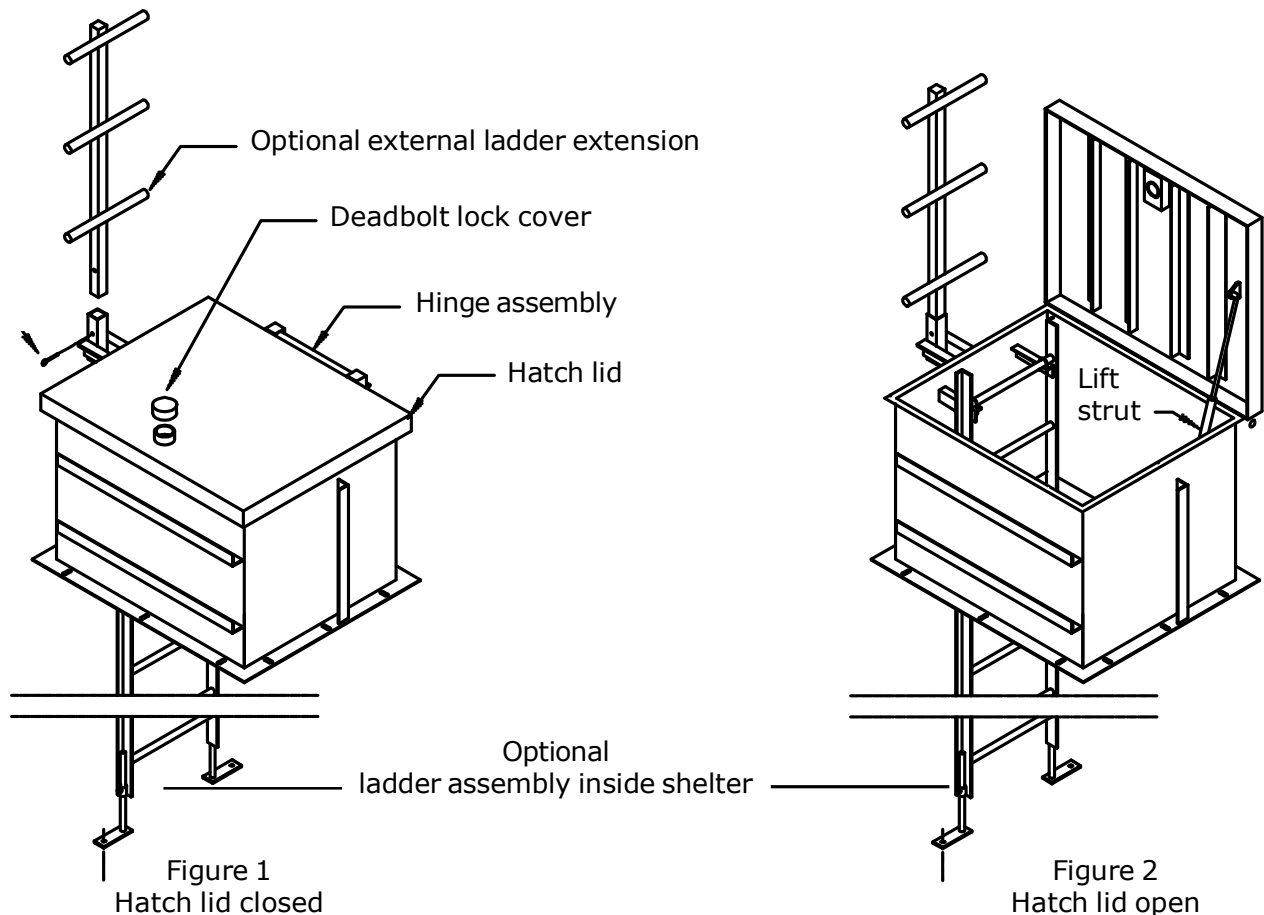

## Options

### Optional Viewers

The riser hatch can be supplied with a “peep sight” wide angle viewer strategically mounted on each of the four walls. They are mounted six inches below the hatch. This gives you the ability to see what is directly around your hatch before opening it.

### Optional emergency escape jack

This 3 ton bottle jack can be deployed if trees fall on top of your hatch. In the stowed position, it nests down behind the ladder. It must be rotated up into position before use - but you do not have to climb a ladder with a jack to deploy it.

### Optional external ladder extension

The riser hatch can be ordered with a removable above ground extension ladder for assistance and added safety for personnel entering or exiting the shelter. It fits into a socket welded onto the outside of the riser.

### Optional internal ladder assembly

The riser hatch may be ordered with a bolt on ladder assembly. This heavy duty steel ladder is rated for 300 pounds. It is built to order so it fits your shelter with the proper dimensions — the bottom rung is between 6 and 12 inches off the floor, the top rung is 6 inches from the top of the riser, and all the rungs in between are 12 inches apart with the proper toe clearance from the wall. See page 5 for ordering details.

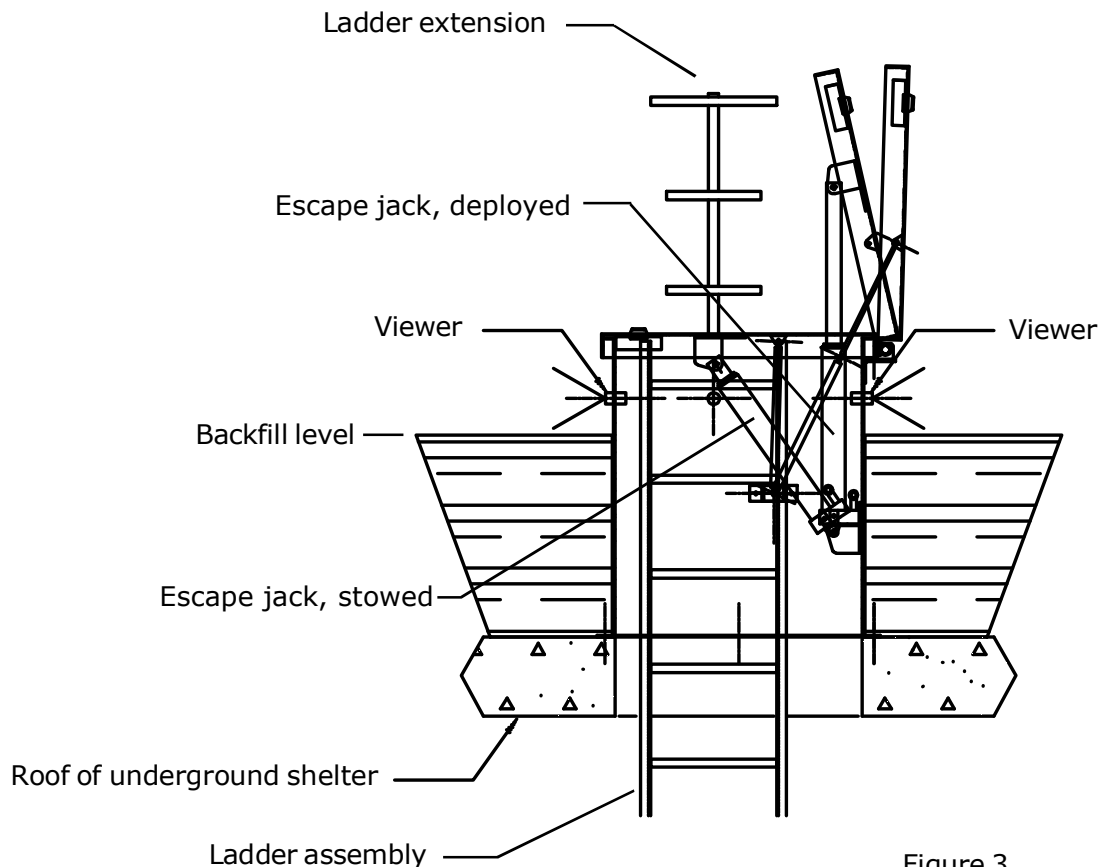
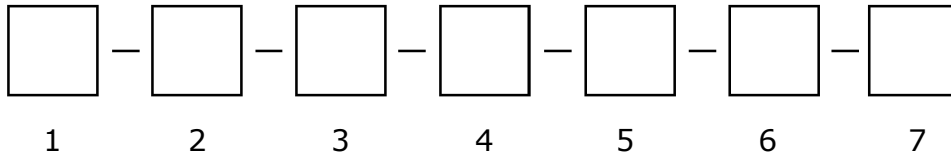

Figure 3  
Viewers, jack, and ladder extension

## Ordering your hatch ladder system

Generate the part number that will be used to build your hatch:



1. Left hand or right hand hatch - see page 6. Enter L or R.
2. Z1 dimension, height of riser - see below. Enter height in inches.
3. Z2 dimension, total height of shelter - see below. Enter height in inches.  
Please note: this dimension is only needed if you are ordering the optional internal ladder assembly - box 7.
4. Viewers - see page 7 - also see curb height below. Enter Y or N.
5. Integrated emergency escape jack - see page 8. Enter Y or N.
6. External ladder extension - see page 9. Enter Y or N.
7. Internal ladder assembly - see page 10. Enter Y or N.

Example: (L-32-88-Y-Y-N-N) is a left hand hatch with viewers, with the emergency jack, and without any ladders.

Note — see dimensional constraints on page 11 before generating your part number.

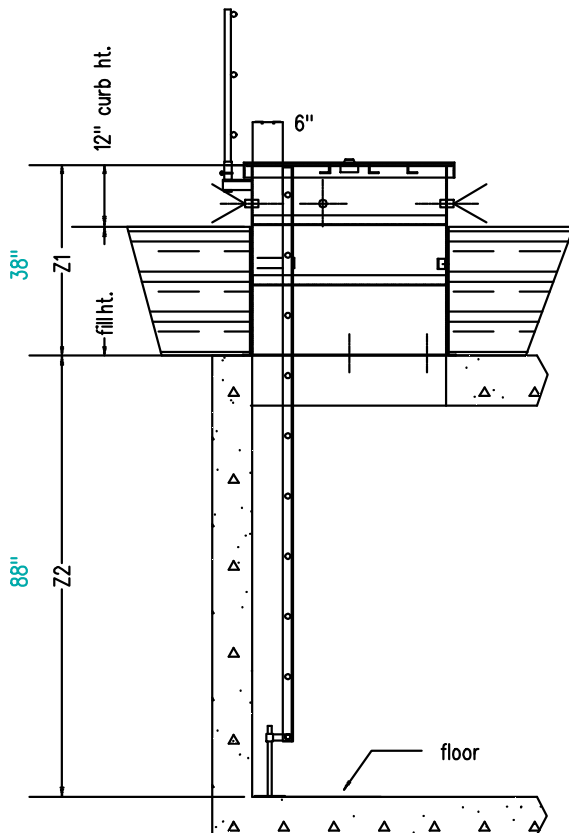

Figure 4  
12 inch curb height  
for hatch with optional viewers

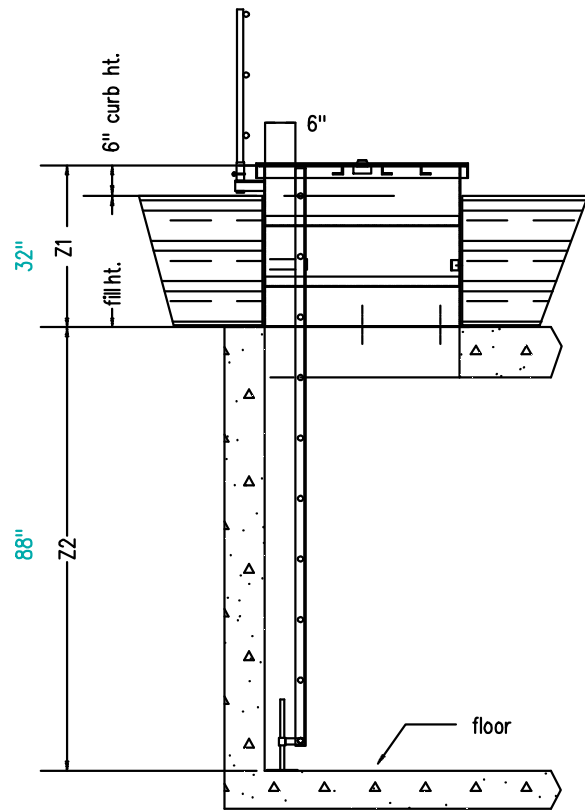

Figure 5  
6 inch curb height  
for hatch without optional viewers

## Left hand or right hand hatch

### Left hand hatch

As you face the hatch, the lift strut is on your left, the optional ladders are on your right. The optional emergency escape jack stows behind the internal ladder.

### Right hand hatch

As you face the hatch, the lift strut is on your right, the optional ladders are on your left. The optional emergency escape jack stows behind the internal ladder.

In box 1 on page 5, enter "L" for a left hand hatch or "R" for a right hand hatch.

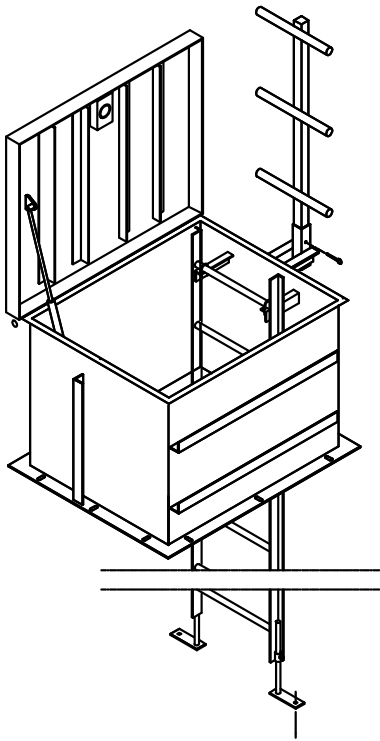

Figure 6  
Left hand hatch

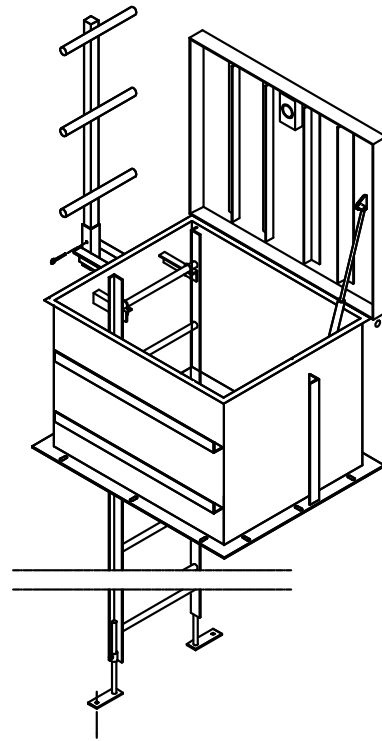

Figure 7  
Right hand hatch

## Viewers

This option will give you four wide angle optical viewers — one mounted on each wall of the hatch. They are located 6 inches from the bottom of the hatch lid, centered on the front and back walls, and slightly offset on the side walls. These “fish eye” viewers feature optical glass lenses and are UL listed for use on fire doors rated up to 1½ hours.

The viewers require a curb height of 12 inches so that the viewers are above ground level. See figures 4 and 5 on page 5 that show this curb height.

In box 4 on page 5, enter “Y” if you want viewers and “N” if you do not.

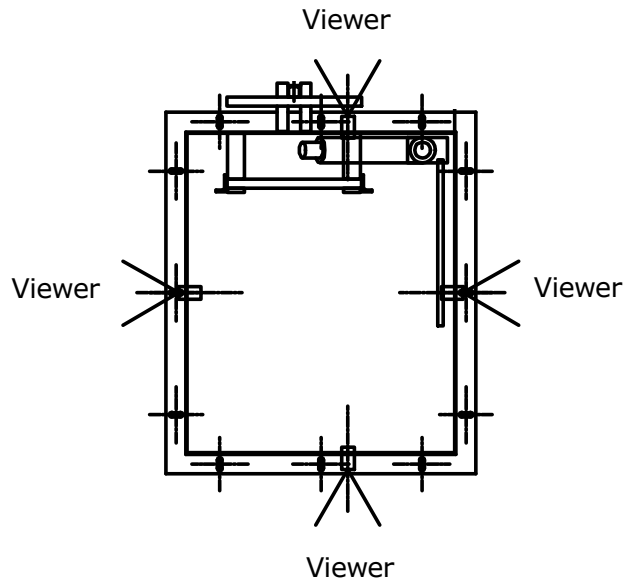

Figure 8  
Viewer positions - top view

## Emergency escape jack

The optional emergency escape jack will allow you to manually open the hatch lid if something heavy is dropped onto the top of your hatch like debris.

When not in use, the stowed position of the jack is behind the ladder. It must be rotated up into the deployed position and a pin inserted through the top anchor point and the jack shaft before use.

In box 5 on page 5,  
enter "Y" if you want this option  
and "N" if you do not.

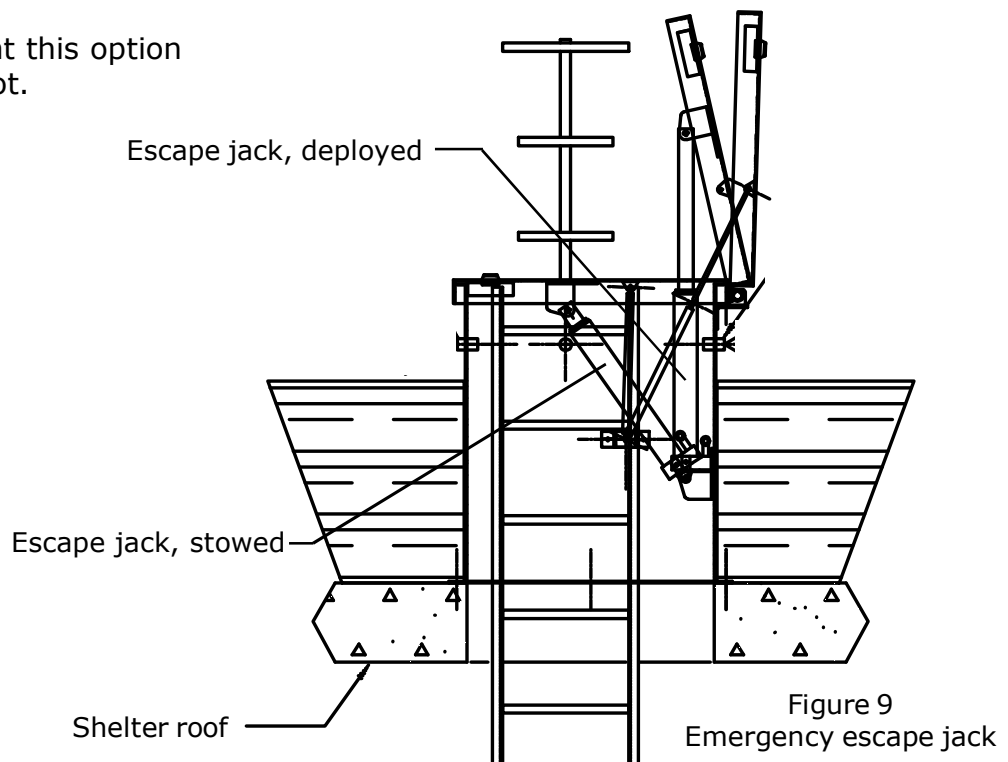

## Emergency escape jack operation

1. Remove jack handle from behind the second ladder rung
2. Close the bleed valve at base of jack
3. Remove the clevis pin from ram shaft
4. Place the ram shaft into upper anchor alignment by pumping the jack handle
5. Replace the clevis pin
6. Operate the handle to jack open the hatch

### Caution

The rating of the jack is 3 tons under optimal conditions, but the load location on the top of the hatch lid may reduce this rating. Also - 3 tons of pressure will deform the top lid. This jack is to be used only in an emergency as the top lid may be damaged.

### Please note

The jack ram hole location in its stowed position is designed to be at rest a distance of 1.1/2" lower than the anchor hole location. This is a safety precaution in order to help insure proper clevis pin placement in cases where the top lid may be potentially distorted due to heavy falling debris. Distortion may occur during jacking in cases where extremely heavy debris has come to rest on the hatch lid.



## External ladder extension

The external ladder extension assists with entering or exiting the hatch by allowing a stable hand hold above the top level of the hatch.

It can stow inside the shelter and be brought up when needed. It fits into a socket that is welded to the side of the hatch with a capture pin.

In box 6 on page 5, enter "Y" if you want this option and "N" if you do not.

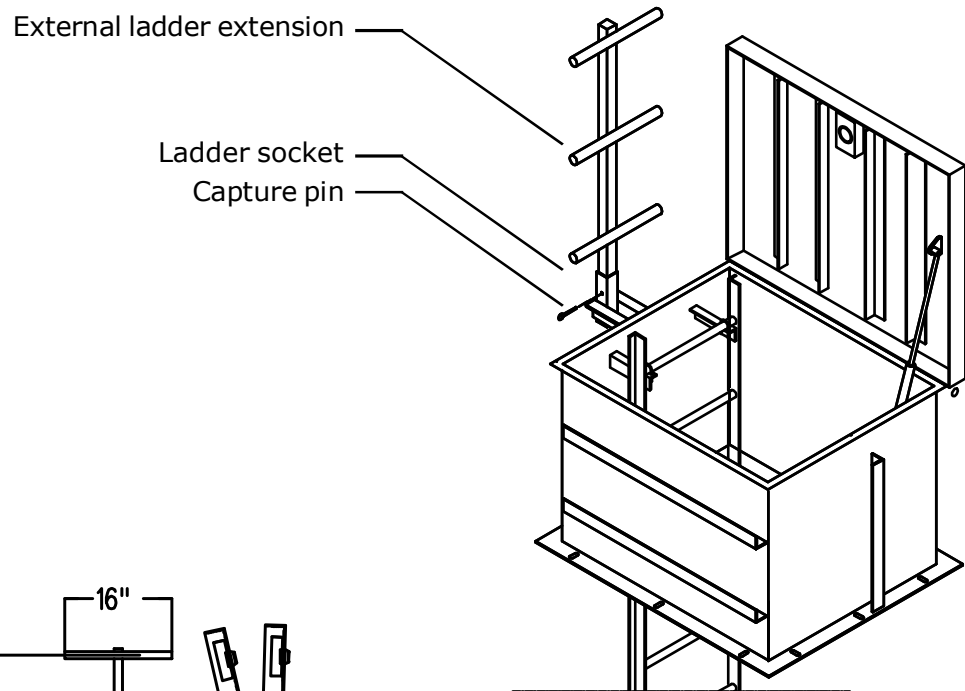

Figure 10  
External ladder assembly

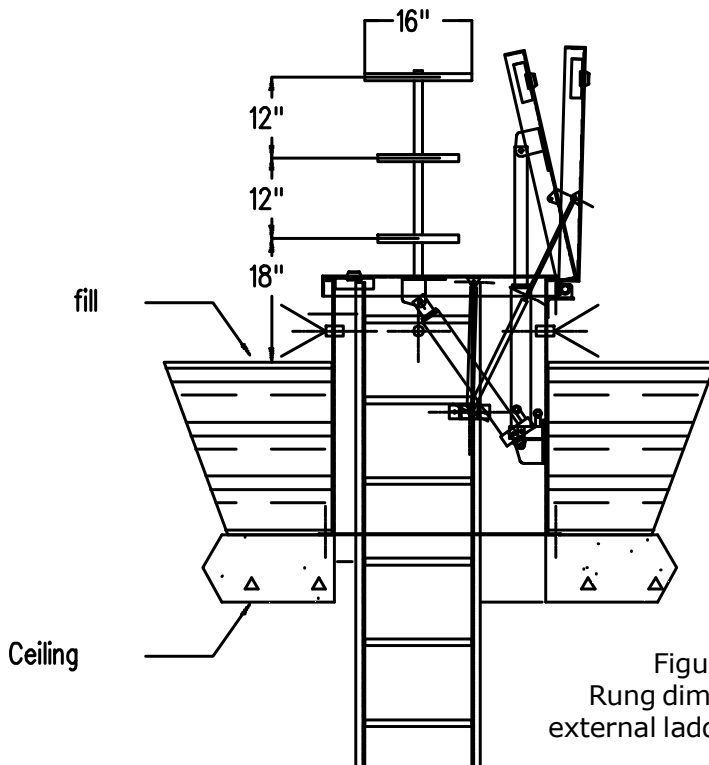

Figure 11  
Rung dimensions of  
external ladder extension

## Internal ladder assembly

The ladder assembly mounts to the inside of the hatch and the floor of the shelter. The rungs are 17.5 inches wide and the outside width is 20 inches.

**Please note:** this ladder has a rung every 12 inches to comply with building codes. Since shelters come in all different heights, the footer assembly that connects the ladder to the floor is adjustable. This will make the bottom rung between 2 and 10 inches off of the floor. We have included the calculations for determining the height of the ladder and the height from the floor to the bottom rung on pages 16 and 17.

The dimension from the top of the hatch to the first rung is set at 6 inches. The dimensions between each rung is set at 12 inches. The dimension from the floor to the first rung is variable between 6 and 12 inches.

The height of the riser (Z1, page 5) and the height of the shelter from the floor to the **top** of the ceiling (Z2, page 5) are used to determine the ladder height, number of rungs, and the height of the first rung off of the floor. See figure 4 and 5 on page 5 for where these dimensions are taken.

In box 7 on page 5, enter "Y" if you want this option and "N" if you do not.

## Calculating the height of the first rung from the floor

This example uses several variables:

DO = distance, floor to top opening + Z1 + Z2

TD = distance, required for top clearance 6", (fixed dimension)

BD = distance, required for bottom clearance = 2 inches, (fixed dimension)

OC = distance, overall top and bottom clearances TD + BD = 8" (fixed dimension)

RC = ladder rung count  $DO - OC / 12 + 1$  (rung) - BD

Example:

To calculate a ladder rung count for a DO distance of 146"

$146" - 8" = 138" / 12" = 11.5 + 1$  (rung) = 12.5 rungs

To convert the decimal to actual bottom clearance from first rung center to floor.

Multiply the decimal by 12 + (BD) 2 inches

$0.5 \times 12 = 6" + 2" = 8"$  actual clearance from first rung center to floor.

Result:

A 12 rung ladder with an 8 inch clearance distance from the floor to the 1<sup>st</sup> rung center.

## Dimensional constraints

The minimum height of a riser hatch (Z1 dimension) that includes a lift strut is 6 inches. The minimum height of a riser hatch (Z1 dimension) that includes the optional bottle jack is 28 inches. The maximum height of a riser hatch (Z1 dimension) is 43 inches. The largest hole size that a riser hatch can be mounted on is 32 by 38 inches.

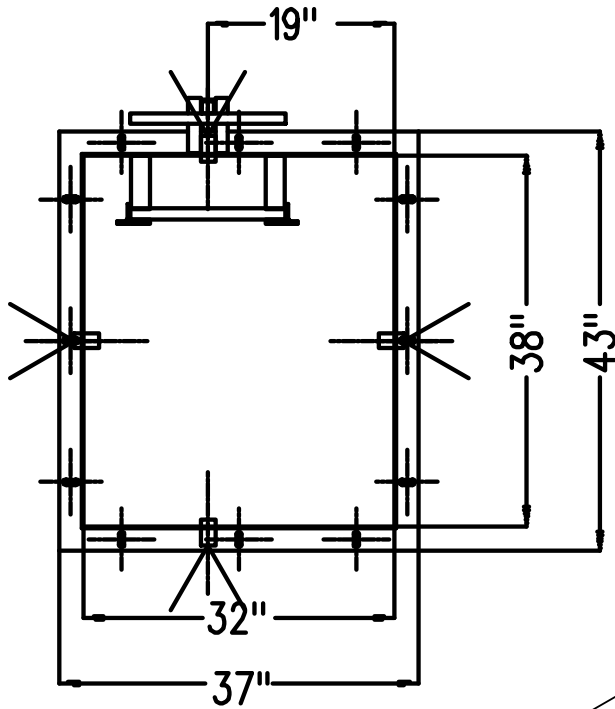

Figure 12  
Footprint and  
free opening dimensions

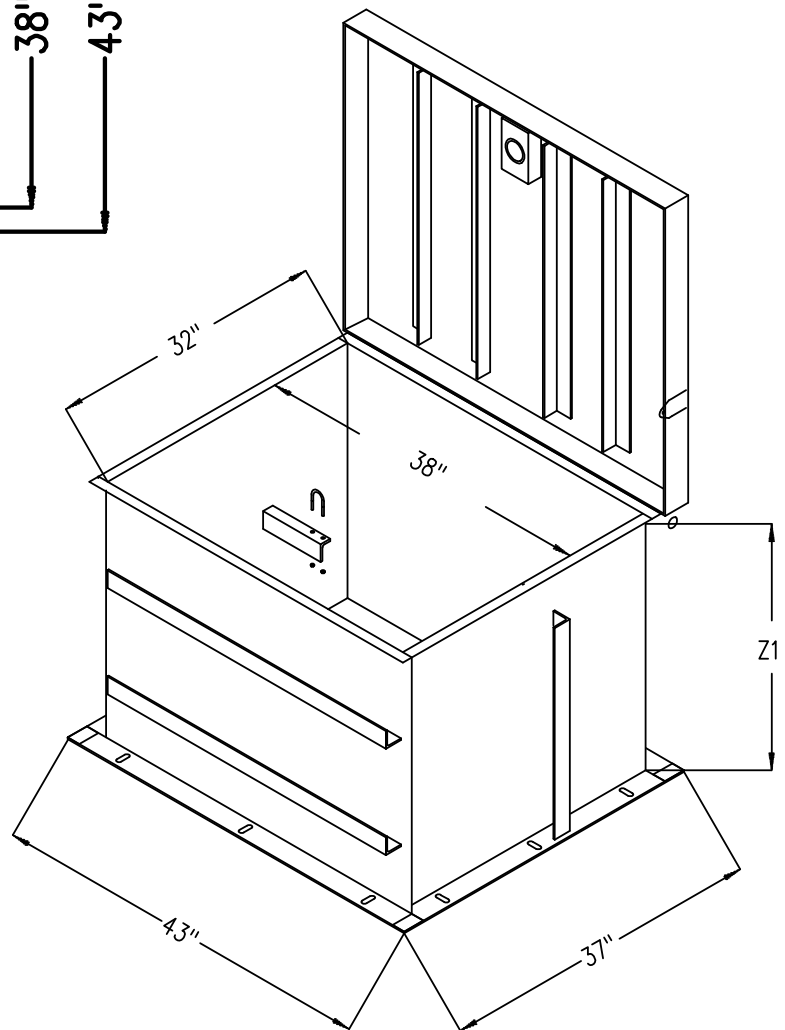

Figure 13  
Envelope dimensions

# Installation

## CAUTION — HEAVY WEIGHT

The riser and ladder assembly weigh several hundred pounds.

It is the responsibility of the installer that proper lifting equipment be used for these procedures and that the installer has sufficient experience, skill, and knowledge to accomplish these tasks safely.

## Hatch riser installation

See figures 13 and 14

## Ladder installation

See figures 15 and 16

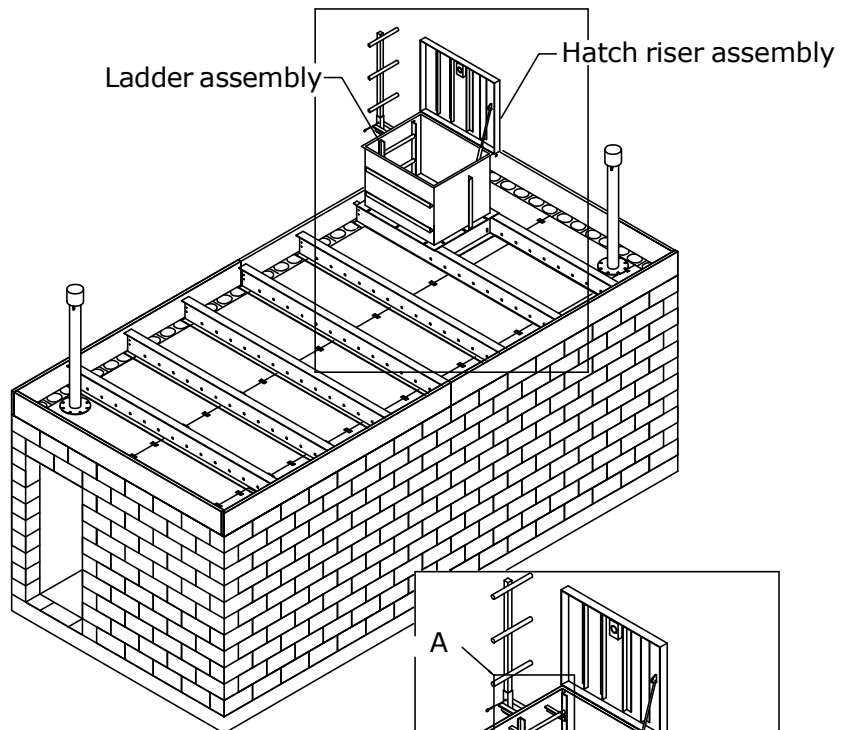
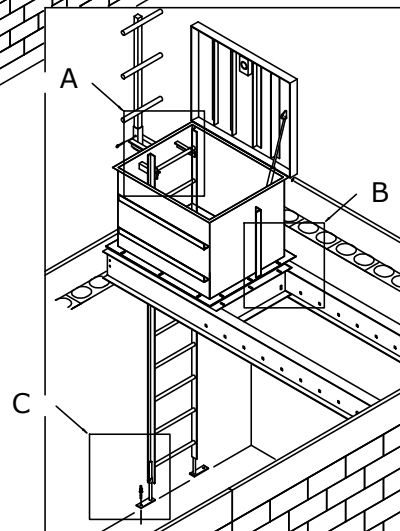

Figure 14



## Mounting the riser over the ASR shelter

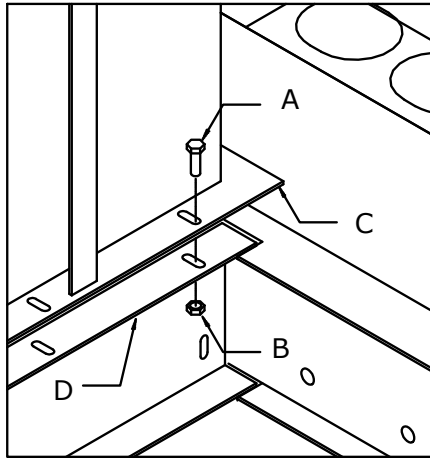

Figure 15

- A. 12 each Bolt 3/8-16 x 1.3/4" length
- B. 12 each Hex nut 3/8-16
- C. Riser mounting flange
- D. Truss mounting flange

This procedure will require the addition of the special riser truss kit, provided with the ASR roof kit.

1. Apply a liberal coat of weather resistant silicone sealant over the edges of the openings surface face where the riser mounting flange bottom face will mate.
2. Install and tighten the provided hex bolts, washers and nuts as shown.

## Mounting the riser on a concrete shelter

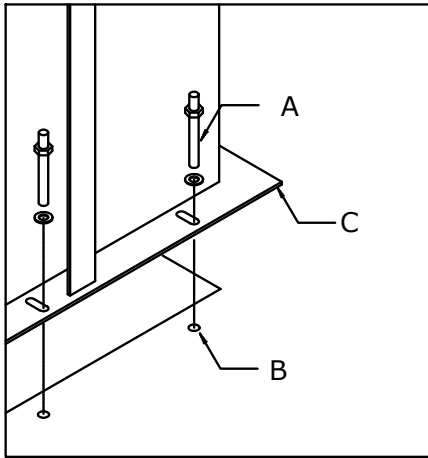

Figure 16

- A. 12 each concrete wedge anchor studs - 1/2" x 6" length
- B. 12 each 1/2" drilled hole with provided masonry drill bit
- C. Riser mounting flange

**Note:** the concrete opening may not exceed 32" x 38"

The gas spring (lift strut) on this hatch causes a little bit of twist in the unit when it is unanchored. The twist is enough to misalign the lock bolt and hole.

Therefore, it is important that this hatch is installed with the gas spring removed.

Once the hatch is installed the gas spring can be reinstalled with out it causing any significant twist.

This hatch is supplied with concrete wedge anchors and a properly sized masonry drill bit.

1. Using the center of the slots in the riser base flange as a template, locate (mark) the hole locations for the anchors.
2. Remove the hatch and drill the holes for the stud anchors. See page 9 for hole depth and complete wedge anchor installation instructions.
3. Clean all of the dust and debris out the holes. Tap the anchors into place with a hammer.
4. Apply a liberal coat of weather resistant silicone sealant on the bottom of the base flange.
5. Remove the lift strut and replace the riser assembly squarely over the opening and insert the stud anchor assemblies through the riser bottom flange into the drilled hole in the concrete.
6. Tighten all anchor stud nuts to (60 ft-lbs) in a cross pattern.
7. Apply a bead of the same sealant on the outside lip of the base flange and inside the base between the steel and concrete.
8. Replace the lift strut.

## Mounting the riser on a steel shelter

The hatch frame is constructed from A36 steel and finished with a coat of primer. It can be welded or bolted onto the top of a steel shelter. If welding, a continuous bead on the inside of the frame is recommended. If bolting, use sealant as described above.

If the shelter has a corrugated roof - such as shipping container, additional sealant or spray foam will have to be used to seal it to the shelter.

## Installing the internal ladder assembly

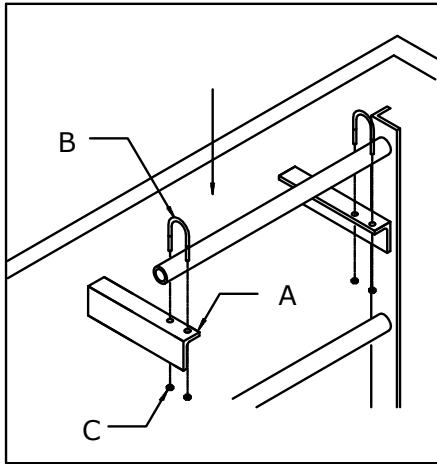

Figure 17

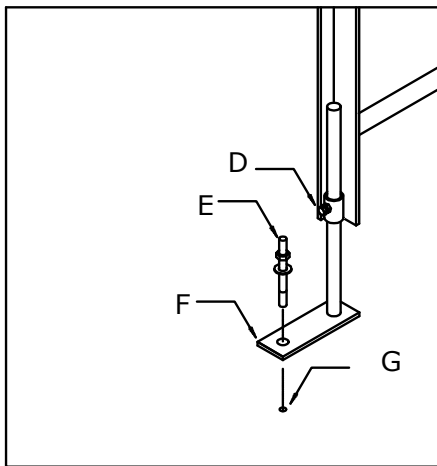

Figure 18

- A. 2 each support brackets
- B. 2 each U-bolts
- C. 4 each hex nuts
  
- D. 2 each locking bolt
- E. 2 each concrete anchor stud
- F. 2 each drilled holes using provided masonry drill bit

1. Pass the ladder down through the riser opening and rest the second rung on the top support brackets as shown.
2. Insert the provided U-bolts over the ladder rung into and through the support bracket holes and install and tighten provided hex nuts.
3. With the ladder hanging straight loosen the bottom foot locking bolt and lower the mounting foot to the floor and retighten the locking bolt, repeat this procedure for the opposite side.
4. Insure that the ladder is positioned in a true vertical attitude and using the foot as a drill template install the provided anchor stud kit using the same procedure as described above.

Concrete Fasting Systems  
Wedge Anchor, Thunder Stud®  
1231 E. 26<sup>th</sup> Street  
Cleveland, Ohio 44114

Phone 888-498-5747  
Fax 216-357-7435  
7:30 – 5:00 Eastern Time

<http://www.confast.com/>

## Installing the concrete wedge anchors

Included with the hatch are Concrete Wedge Anchor "Thunder Stud®" ½-inch diameter by 4.1/4-inch length and the proper masonry drill bit for these fasteners.

### Concrete Wedge Anchor -Technical Information

The ThunderStud® wedge anchor consists of two pieces, permanently pre-assembled into a single unit. The carbon steel rod is threaded for a portion of its length. The extreme end of the threaded portion is rounded to protect the threads from damage while the anchor is being driven into the hole drilled in the concrete. The other end of the rod has a necked down diameter, which runs for a short distance, at the end of which it tapers outwardly to the full diameter of the rod. A precision formed universal clip made of carbon steel is permanently assembled around the necked down diameter to complete the anchor. Each package contains the correct number of nuts and washers.

#### Concrete Wedge Anchor - Approvals:

Listed by Underwriters Laboratories (UL), International Conference of Building Officials (ICBO) carbon steel only, Board of Standards and Appeals (BSA), City of L.A. Meets or exceeds U.S. Government G.S.A. Specifications FF-S-325 Group 11, Type 4, Class

#### Concrete Wedge Anchor - Applications:

Medium to heavy duty into concrete.

#### Concrete Wedge Anchor - Installation:

(1) Drill hole into concrete with a carbide tipped masonry drill bit conforming to ANSI B94, 12-77, the same size as the ThunderStud® wedge anchor. If the fixture being fastened is in place and being used as a template to locate the ThunderStud® anchor, the mounting hole in the fixture should afford clearance for the universal wedge clip on the stud. (2) Clean hole, place the ThunderStud® wedge anchor through the hole in the fixture or directly into the concrete and hammer it in to the drilled hole until the threads are below the surface of the fixture/concrete. (3) Turn the nut by hand until the unit is snugged up. Tighten the nut with a wrench, approximately three or four full turns, to complete the fastening.

#### Concrete Wedge Anchor - Anchor Length:

Minimum embedment, plus fixture, plus nut and washer. The ThunderStud® wedge anchor requires no maximum hole depth. **The depth of the hole in the concrete should be the length of the wedge anchor minus the thickness of the material being fastened.** This will result in some extra depth to accommodate a minor amount of concrete cutting which may not be able to be cleaned out of hole.