

American Safe Room

Explosion Resistant Pre-hung Double Leaf Blast Door

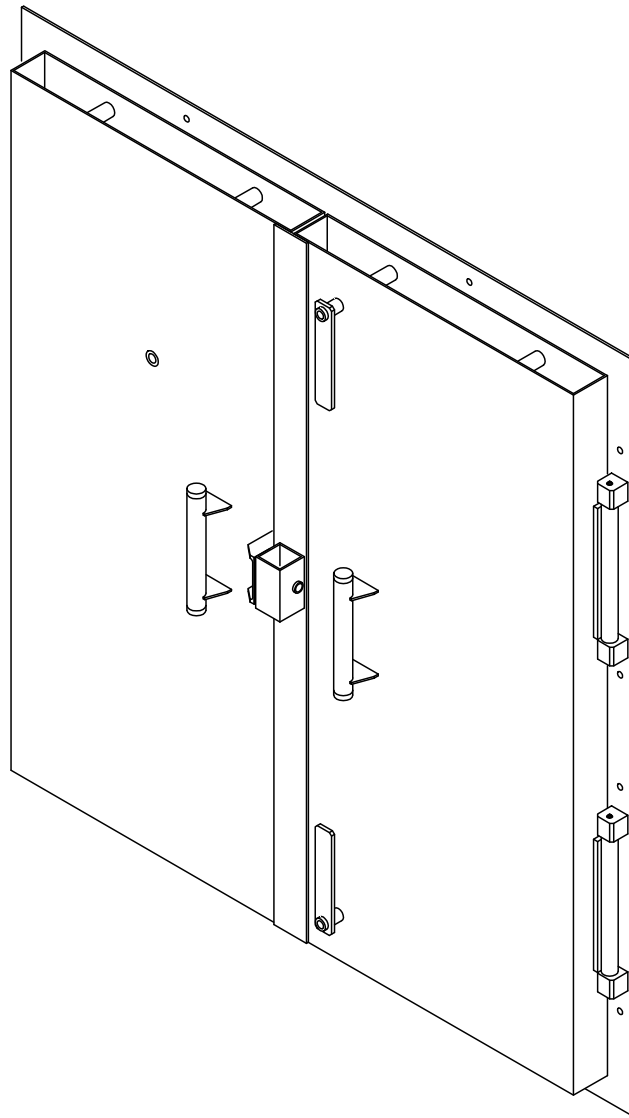

Drawing number: ASR-50-DBL-BD
Revision: B2
April 3, 2015

Table of Contents

Description 3

Strength..... 4

Part number 5

Swing geometry 6

Wall opening size 7

Outside operators 8

Assault resistant security latches 9

Outside security hasp assembly and viewer 10

Closing and latching the blast door 11

Installation 12 - 15

 Step 1 — preparing for installation 12

 Step 2 — placing the first leaf assembly 13

 Step 3 — adjusting the leaf assembly for proper alignment 14

 Step 4 — setting and adjusting the second leaf 15

Wall capture brackets 16

Sealing the inside door frame lip 16

Filling the door with concrete 16

Concrete wedge anchor — technical information 17

Contact information

American Safe Room
868 Murdock Drive
Oakland, OR 97462

Telephone: 541-459-1806
FAX: 503-212-6695

Websites: www.AmericanBombShelter.com
www.AmericanSafeRoom.com
www.AmericanIsolationRoom.com

Description

ASR-50-DBL-BD Blast Door is a pre-hung, explosion resistant blast door that offers outstanding protection from extremely high pressure blast waves like those produced by a large conventional or nuclear device detonated in relatively close proximity. This door is rated to withstand high pressure waves up to 7,200 pounds per square foot — that is 50 pounds per square inch (PSI).

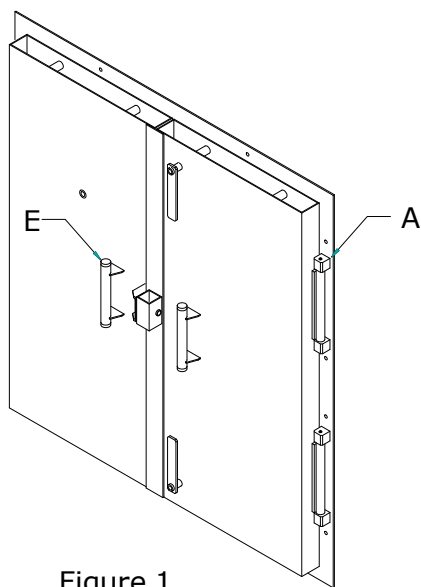

Figure 1

Hinges (A)

The four vault style 1.1/2-inch diameter steel hinge pins are machined and polished from 1.1/2" diameter alloy steel (1), rotating in lubricated 60-60 bronze bearing blocks (2, 3) with re-grease able fitting (4).

This robust assembly allows for both high strength and precise closure to insure the proper alignment and compression of the gas seal.

Door frame (B)

The heavy steel frame is constructed from 5-inch by 3-inch by 1/4-inch thick steel L-shaped angle with the 3-inch leg serving as the centering guide for hanging the door. The 5-inch leg is pre drilled for the included concrete anchoring studs, and serves as a drilling template for locating the drill holes.

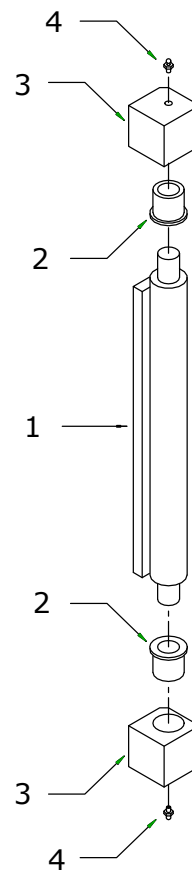

Figure 2

Inside cam latches (D)

The two inside cam latches draw and lock the door tight to the gas seal. The upper and lower latch handles are provided with a built in friction safety clutch to insure that the latch handles do not unintentionally creep from the open condition to the closed or latched condition.

Heavy duty pull handles (E)

Large two handed grip heavy duty handles constructed from steel tube and plate are located on both the inside and outside of the door.

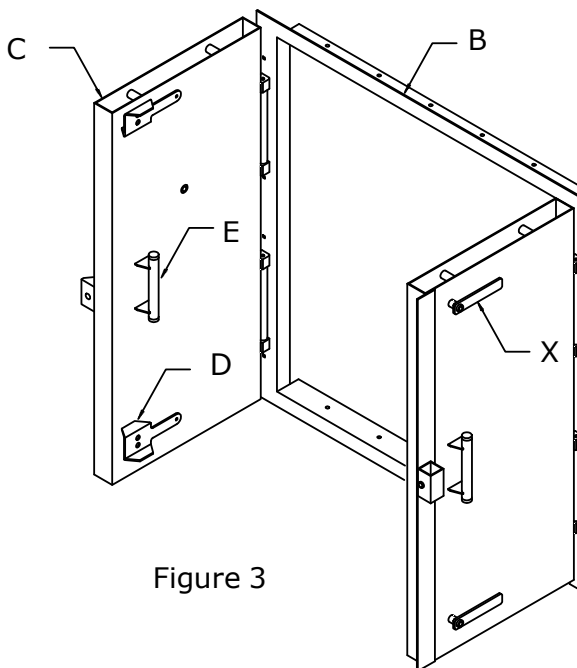

Figure 3

Strength

The ASR blast door features a stronger door leaf design that is a full 5-sided envelope fabricated from 1/4-in steel plate - to be filled with concrete after hanging. This outer skin envelope design (A, B, C, D) affords a greater strength to weight ratio than does early style rebar reinforced poured in place doors of the 1950's. The reason is simple, the outer skin of the envelope becomes the reinforcement steel, this is the element that stiffens the door against failure due to crumbling and buckling.

Example:

An ASR blast door leaf that is 36 x 80 inches is constructed from 1,200 cubic inches of steel, having a pre-fill weight of 340 pounds of steel.

A standard 36 x 80 inch 1950's style rebar reinforced door that is imported from Europe has as it's structure: no steel skins and two courses of 1/2-inch rebar placed on 6-inch centers (5 vertical and 13 horizontally) for 145 feet of total length of rebar which yields a steel weight of weight of 85 pounds.

The 1950's door will take about 2,000 pounds of concrete fill, add this to the rebar weight of 85 pounds for a total leaf weight of approximately 2,085 pounds. The ASR door will take about 1000 pounds of concrete fill, add this to the envelop weight of 340 pounds yielding a total leaf weight of approximately 1340 pounds — **the same strength at almost half the weight.**

In short, the ASR blast door features more steel, less concrete, and equal or better strength. This less weight means less stress on the hinges, latches and walls. Add to that the ease of installation - no need to pour the frame in place or make your own plywood forms for the door.

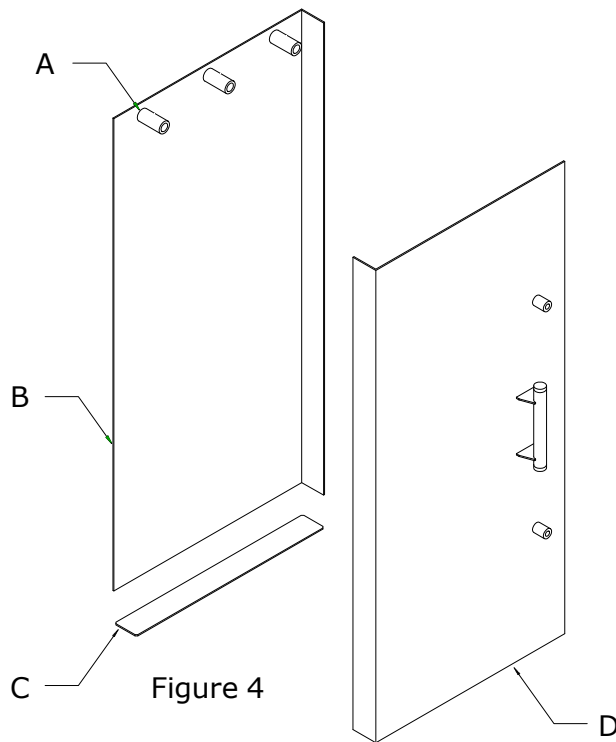

Figure 4

Door leaf construction

- A Lifting point spacers
- B Inside door skin
- C Door floor
- D Outside door skin

Part number

The first step to ordering a blast door is to determine which options are required and create a part number. Every option is explained in this manual on the page numbers references below.

The part number example shown below represents a 72-inch wide x 80-inch high frame size, without outside operators, with assault resistant cam latches and wall capture brackets, with outside security hasp assembly, and without the viewer. You can fill out the part number block at the bottom to show the exact blast door you require.

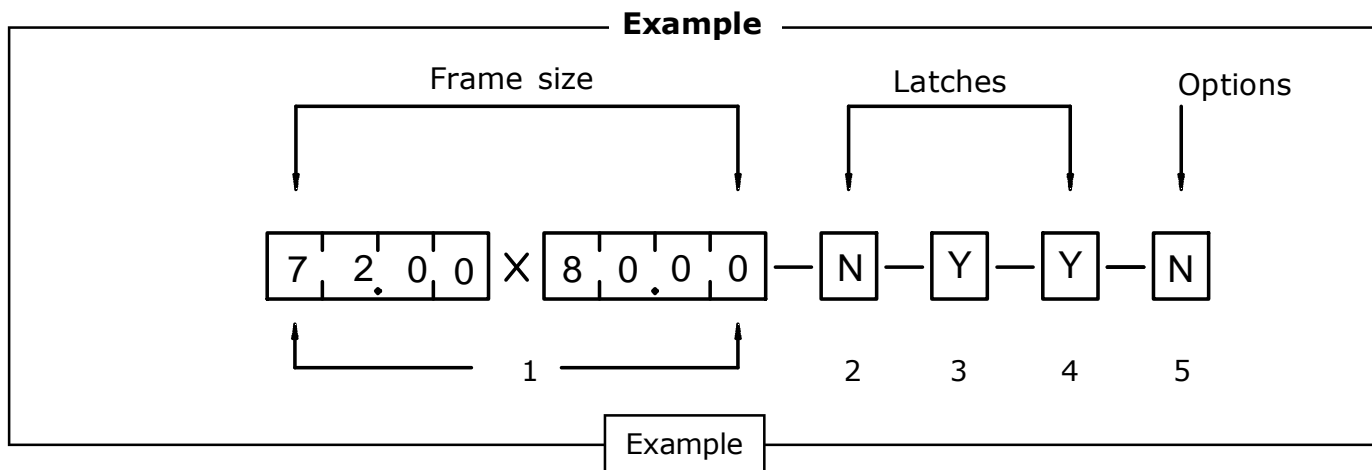

Hand, Frame and Size

1. Size in inches, width (##.##) x height (##.##), see page 7
 72.00 x 80.00 and 96.00 x 80.00 are the standard door sizes.
 Nonstandard door sizes will be charged an engineering fee.
 American Safe Room has built many custom doors and will build to fit your existing opening.

Latches

2. Outside operators, (Y-N), see page 8
3. Assault resistant cam latches and wall capture brackets, (Y-N), see page 9
4. Outside security hasp assembly, (Y-N), see figures page 10

Options

5. Viewer, (Y-N), see figures 10

Enter your part number here

Frame size
Latches
Options

X

-

-

-

-

1
2
3
4
5

Swing geometry

All blast doors must open outward. This is because the extreme forces produced in a high energy explosion must be transmitted directly to the door frame and wall connection.

Note:

- Swing out is always 8" greater than 1/2 the of the door width.
- Clear opening (inside door frame) is always 1/2-inch less than frame size.

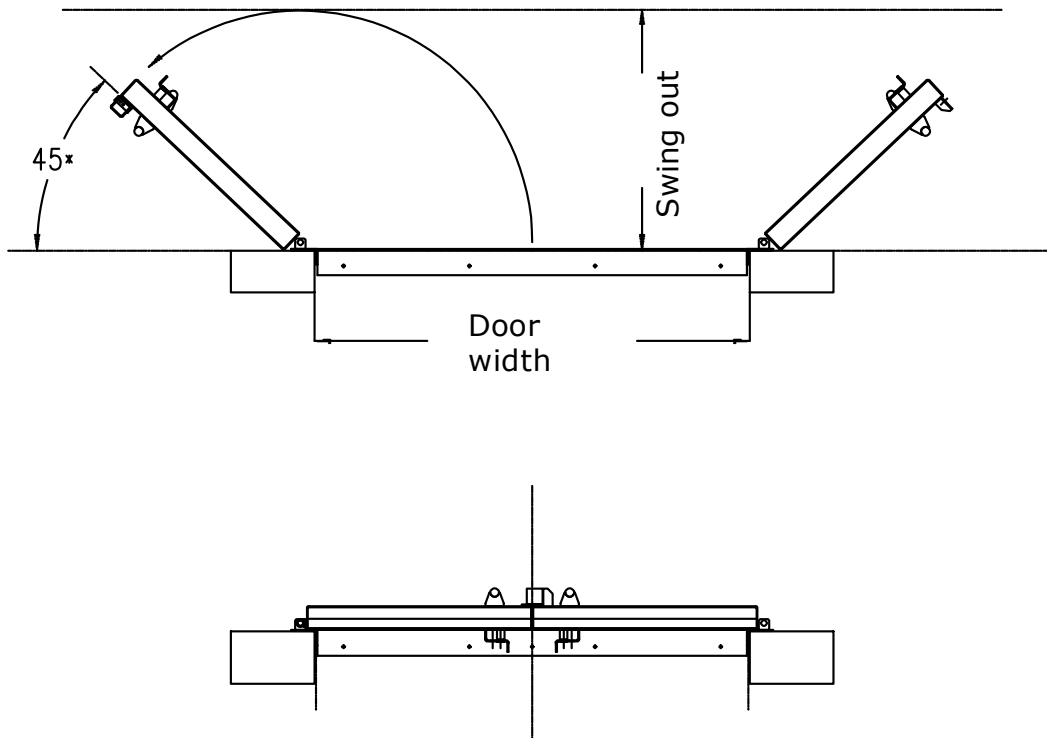

Figure 5

Door and wall opening size

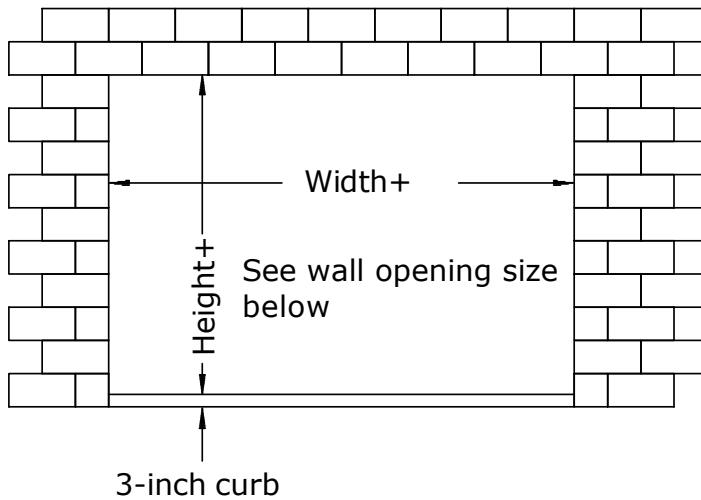
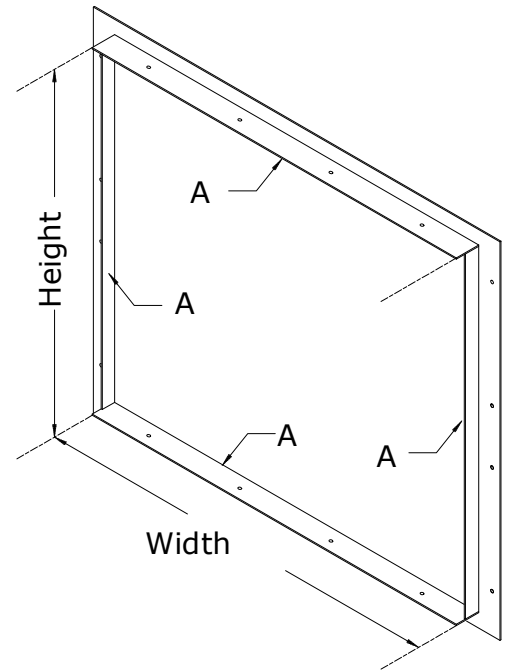

Figure 6



Enter the size (in inches decimal) in box 3 of the part number form.

Standard door sizes

- 72 inches wide by 80 inches high
- 96 inches wide by 80 inches high

Custom sizes

- Please contact American Safe Room to get a quote on a custom door size.

Wall opening size

The outside of the door frame lip Detail A, (that fits into the wall opening) is made to the exact size of the door ordered. To insure a proper fit the wall opening should be made at least $\frac{1}{2}$ inch wider and taller than the door frame lip. Example: a 80 x 80 inch door should have an opening of at least 80.5 x 80.5 inches.

Caution

See section on wall suitability on page 12.

Outside operators

Outside operators are latch handles on the outside of the door that rotate with the inside latches. This option allows you to latch and unlatch the blast door from both the inside and outside.

The outside operator (number 1, below right) works in unison with the inside latch (number 2, right). If you rotate the outside operator, it will rotate the inside cam latch. They are on a common shaft. This option should not be used for secure shelters. Interior blast doors and industrial sites are the most common installations that require the occupant to open and close the door from either side.

To add this option, enter "Y" in box 2 of the part number form on page 5.

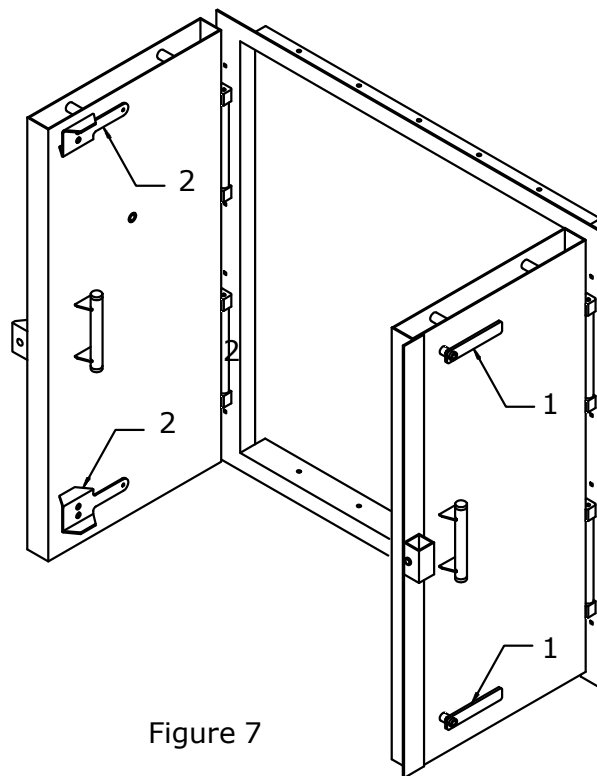

Figure 7

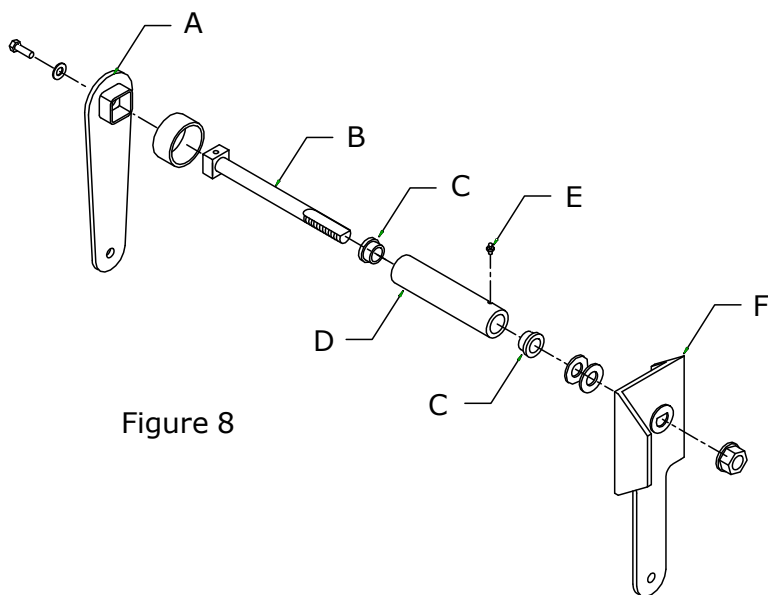

Figure 8

The outside operator handles (A) may be removed when outside access is not desired. The assembly transmits outside rotational force directly to the internal cam latch (F) by means of a $\frac{3}{4}$ -in alloy steel shaft (B) carried by two 60-60 bronze bushings (C) housed inside of the air tight lubrication sleeve (D) with re-grease able fitting (E).

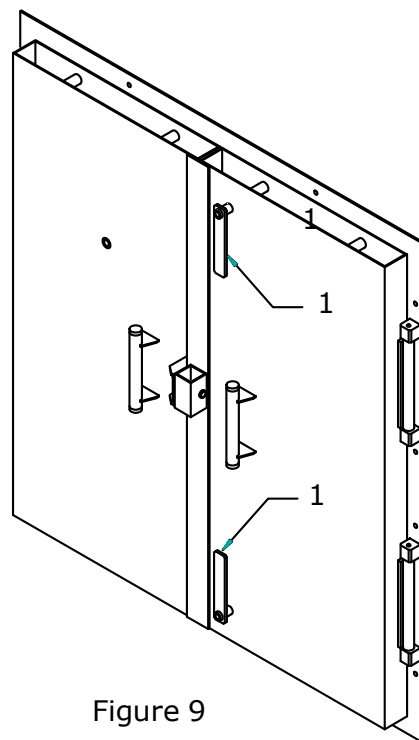

Figure 9

Assault resistant security latches and wall capture brackets

The assault resistant security latches are two additional cam latches (items A, below) on the hinge side of the door leaf and an anti-slip bracket (Item B, below) that keeps the door from slipping downward if the hinges are cut. It's purpose is to hold the door in place even if the outside hinges are attacked by a malicious person trying to gain entrance to your shelter.

The wall capture brackets (items C, below) are steel angles that go from the door frame lip to the inside of the wall. They need to be welded onto the frame lip and fastened to the inside wall **at time of installation**. They fit walls from 6 to 12.5 inches thick. See page 16 for installation instructions.

With this option, the blast door is highly resistant to being defeated from the outside. The door itself is resistant to cutting with a torch due to being filled with concrete. The hinges can be cut off with a torch and the door will stay in place. The frame fasteners can be cut off with a torch - and the frame will stay in place. **This gives the security of a poured-in-place door frame, with the ease of installation of a bolt-on blast door frame.**

To add this option, enter "Y", in box 3 of the part number form on page 5.

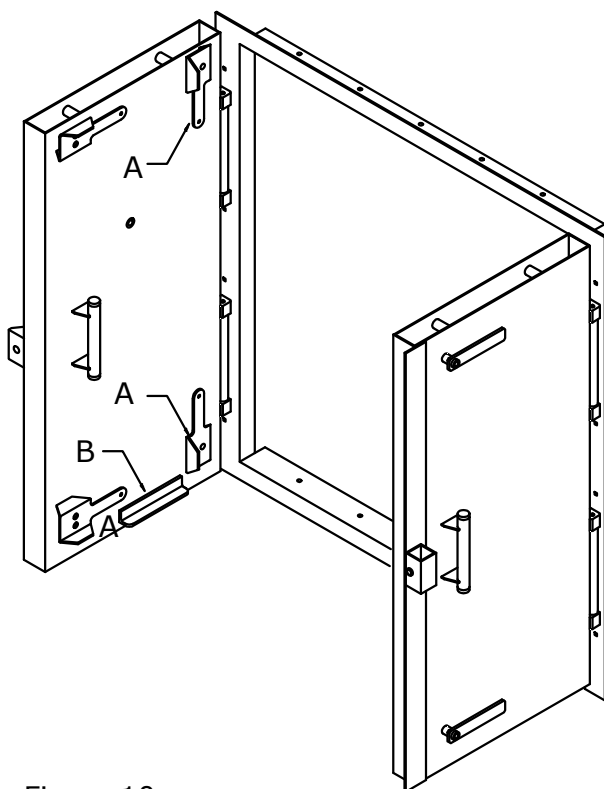

Figure 10
Door viewed from the outside
A - assault resistant cam latches
B - anti slip bracket

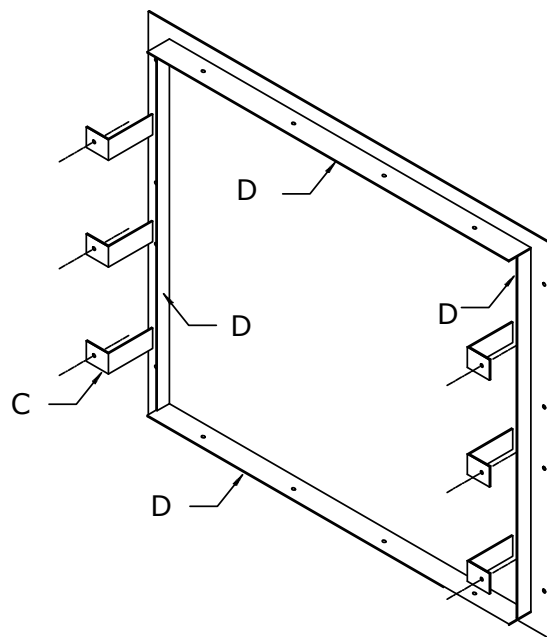
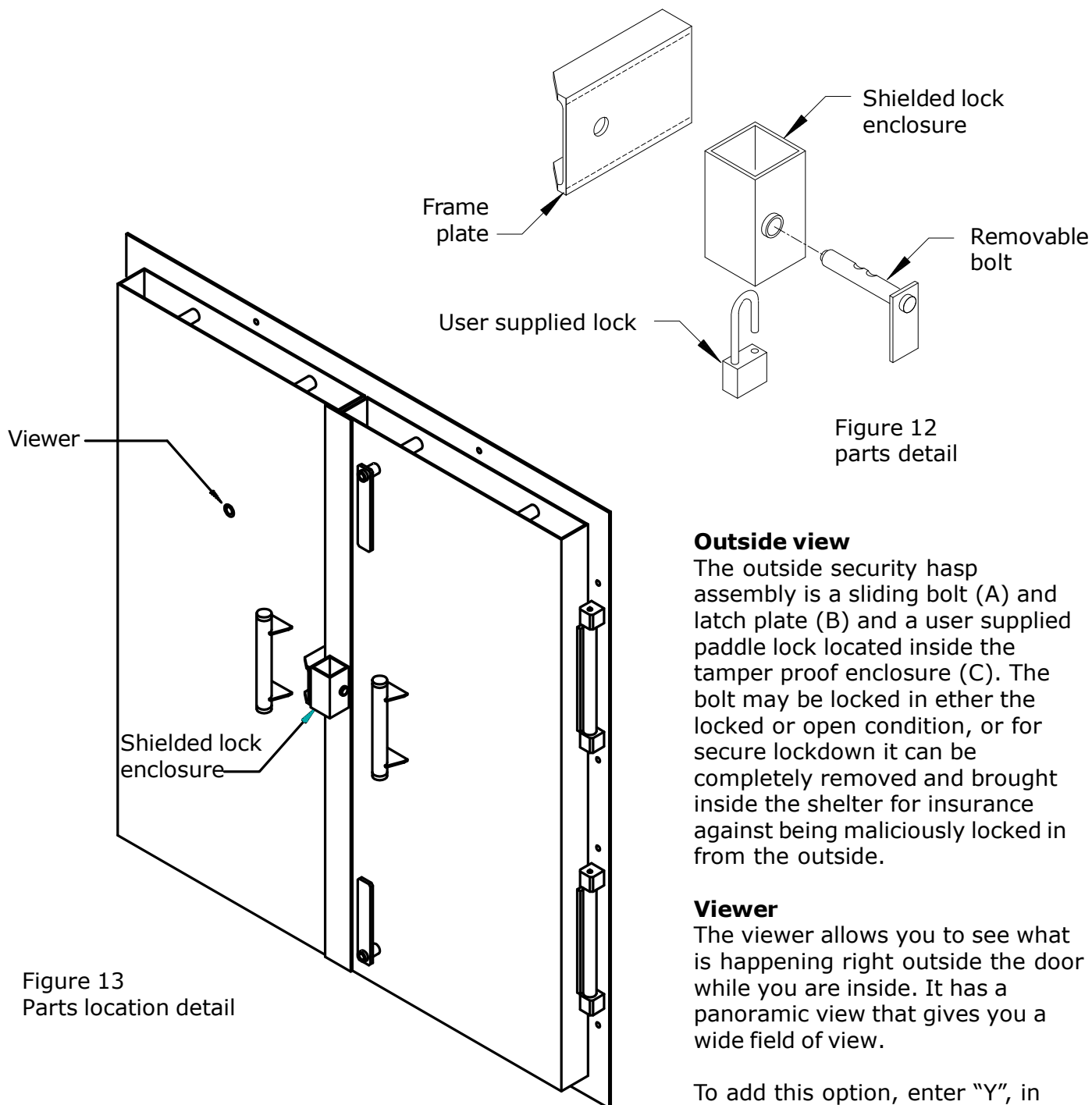

Figure 11
Door frame viewed from the inside
C - wall capture brackets
D - frame lip

Outside security hasp assembly

The outside locking assembly requires a user supplied paddle lock. For your safety the paddle lock and bolt assembly are lockable in both the unlocked and locked condition — you can lock the shelter door closed when it is unoccupied or lock the bolt in the open position if you are in your shelter, but not in lockdown. When you go into lockdown in your shelter, you take the removable bolt and the paddle lock with you inside the shelter to make it harder for a malicious person to lock you inside.

To add this option, enter "Y", in box 4 of the part number form on page 5.



Outside view

The outside security hasp assembly is a sliding bolt (A) and latch plate (B) and a user supplied paddle lock located inside the tamper proof enclosure (C). The bolt may be locked in either the locked or open condition, or for secure lockdown it can be completely removed and brought inside the shelter for insurance against being maliciously locked in from the outside.

Viewer

The viewer allows you to see what is happening right outside the door while you are inside. It has a panoramic view that gives you a wide field of view.

To add this option, enter "Y", in box 5 of the part number form on page 5.

Closing and latching the blast door

Closing and latching the door

The door is brought tight to the gas seal by means of a cam plate system.

By rotating the upper and lower operator handles (A and B) causing the door to draw tight onto cam plate (C).

Caution

The doors are extremely heavy, use extreme caution as not to allow the door to swing closed on fingers or other body parts.

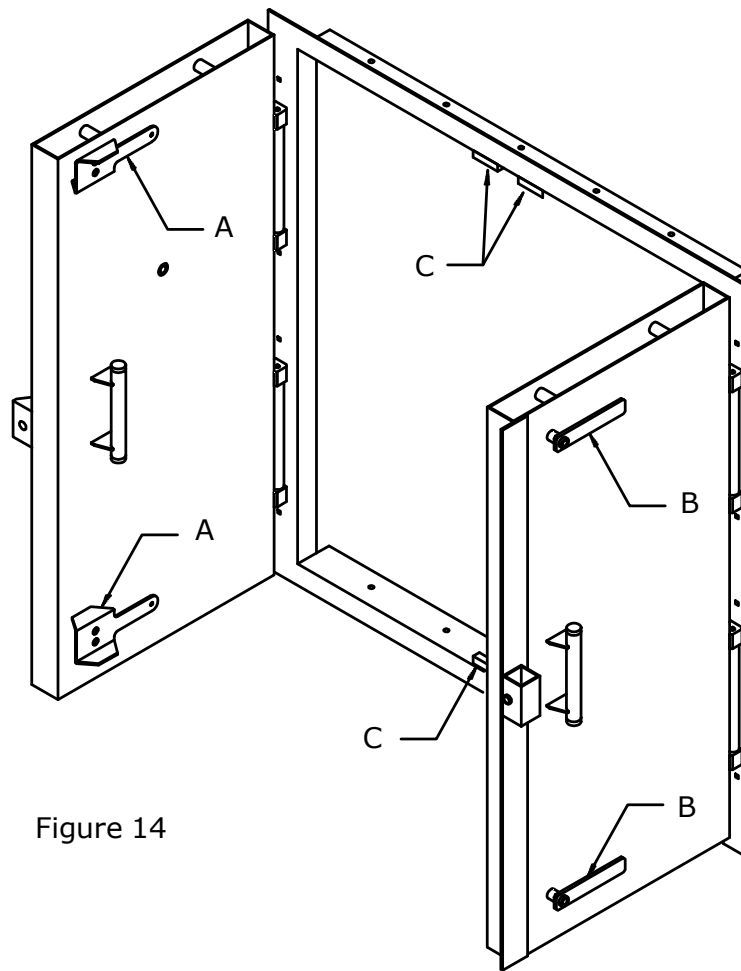

Figure 14

Installation

Wall Suitability

Wall must be constructed of sufficient strength to safely carry the load of the concrete filled doors in the open or cantilevered condition.

Example: a single 48-in wide X 86-in high door leaf filled with concrete would have an approximate weight of 1,950 pounds.

The lever moment is $48/2=24$, $86/24=3.58$, $1,950\#/3.58=545$ pounds

The upper frame half would have a minimum of 3 concrete lag bolts in the shear condition.

This would result in a shear force of 182 pounds on each of the three lag bolts $545\#/3=181.5$. A safety factor of 3:1 is a minimum recommendation, or 545 pounds shear per lag. It is the installers responsibility to insure that these safety requirements are met.

Masonry block walls **without** the added strength of sufficiently sized steel rebar and **without** concrete fill are not suitable for double hung blast doors.

The pre-hung blast door is constructed with two lifting points inside the door envelope. Use only lifting equipment approved for overhead lifting and hardware for this task.

Step 1 – preparing for installation

The double leaf blast door is constructed in two half sections and is designed to be installed one half at a time.

Insure that opening is suitable to accept and hang door.

- Top of curb or slab must be flat and level (item A, below).
- Sides of opening must be parallel and plumb to the slab (item B, below).
- The outside face of the opening at the edges must be flat and square (item C, below).

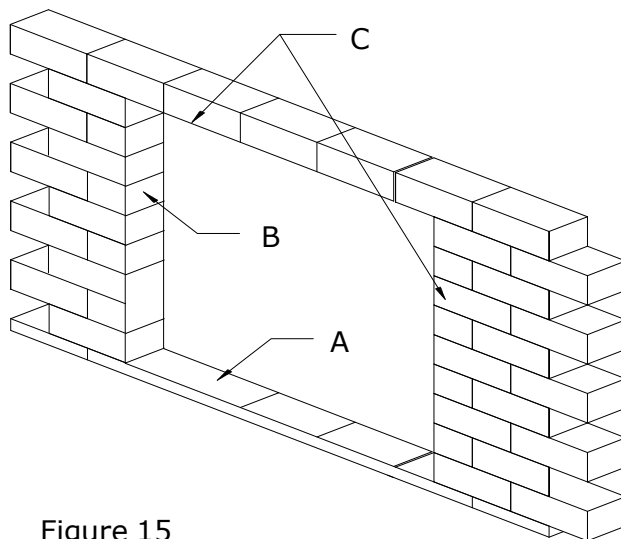

Figure 15

Step 2 – placing the first leaf assembly

Use only certified lifting equipment rated for the load.

Always secure the door leaf shut with the cam latches:

- during all handling and lifting.
- during all filling with concrete.
- during the concrete cure time.

Lift first half door frame assembly into the wall opening and push the door so that the frame lip is fully captured inside the boundaries of the opening. Brace or otherwise secure the door frame assembly so that it can not fall out of the opening.

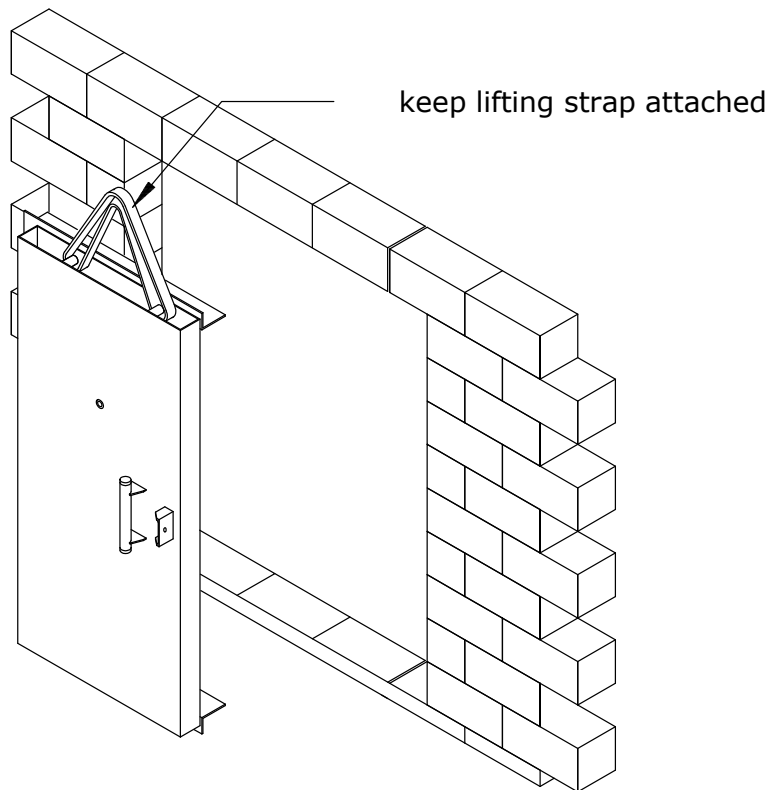

Figure 16

Step 3 – adjusting the leaf assembly for proper alignment

- a. Insure that the door frame assembly sits flat on the bottom curb or slab and nests squarely to the vertical wall.
- b. Using a plumb line or laser level insure that the closing edge of the door is vertically plumb.
- c. Inspect the door to frame fit at the upper and lower gasket for a parallel distance separation or gap of $\frac{1}{4}$ "- $\frac{3}{16}$ "
- d. Install the provided anchor studs as per instruction in this manual (item A below)

It is sometimes necessary to grout or shim the door frame assembly so that the above conditions can be satisfactorily met.

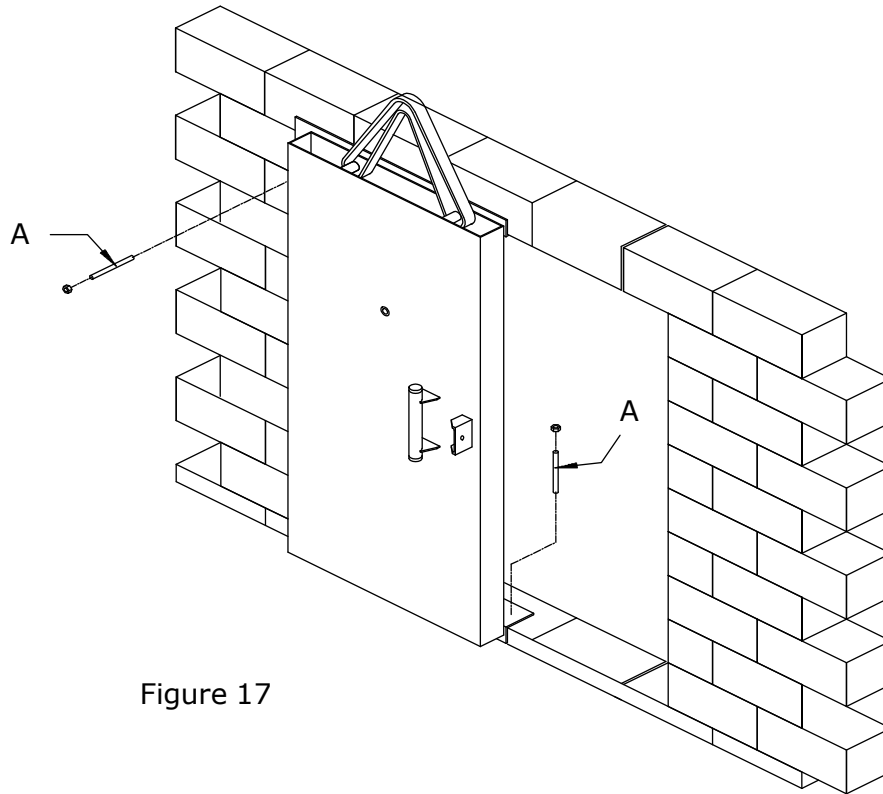

Figure 17

Step 4 – setting and adjusting the second leaf

- a. Set the second door half in place following steps a through d from page 14.
- b. Set the gap distance between the doors edges as shown figure 19 and 19A using the two provided 3/16" thick metal shim bars as spacers.
- c. Install the provided anchor studs as per the instructions on page 17.

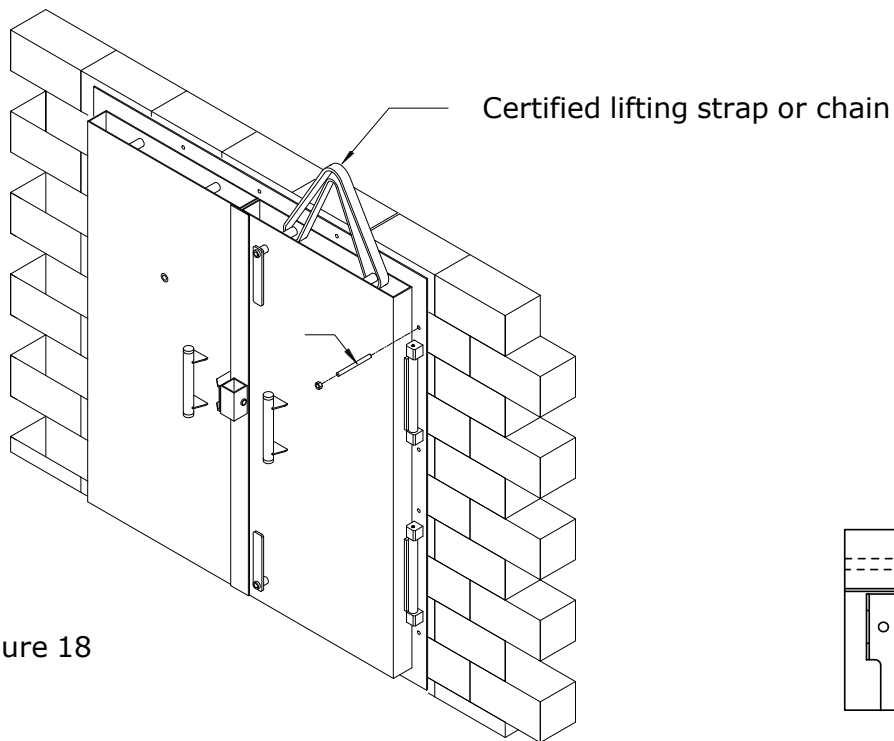

Figure 18

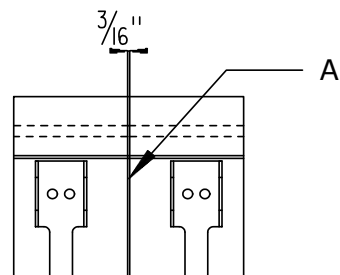

Figure 19A

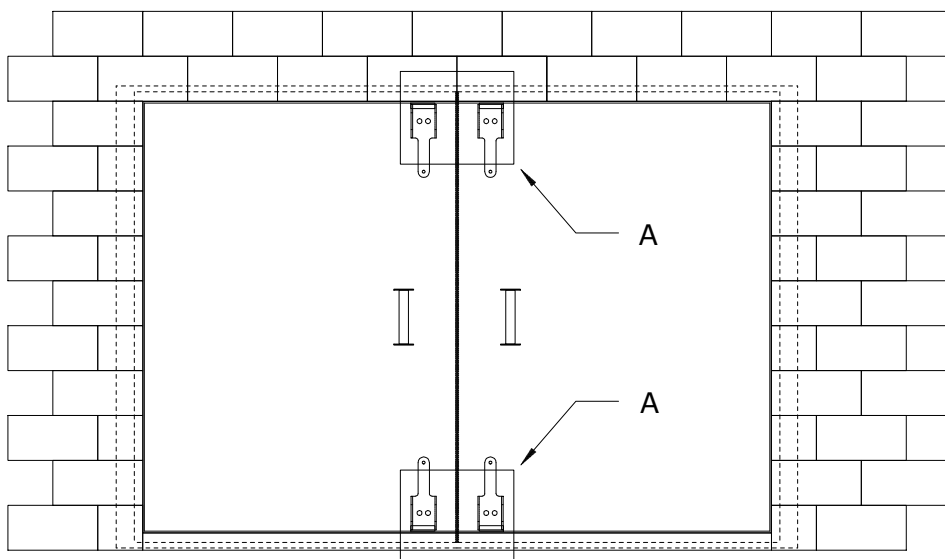

Figure 19

Wall capture brackets

The angle brackets are designed to provide extra security and strength to door loads in the unseating condition. Smaller doors will have four brackets, not six - as shown.

Position angle bracket as shown and cut off the long leg leaving a 1/8-inch weld gap between the frame leg and the angle bracket.

Locate the angle brackets between the door frame anchor studs to avoid interferences of the anchors, and install the provided anchor studs as described on page 15.

Make a full length 1/4 inch vertical fillet weld the across the 4-inch wide strap and the door frame.

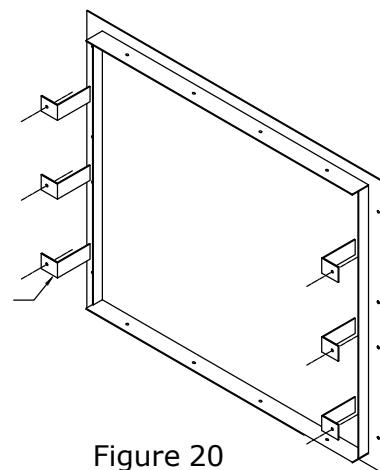

Figure 20

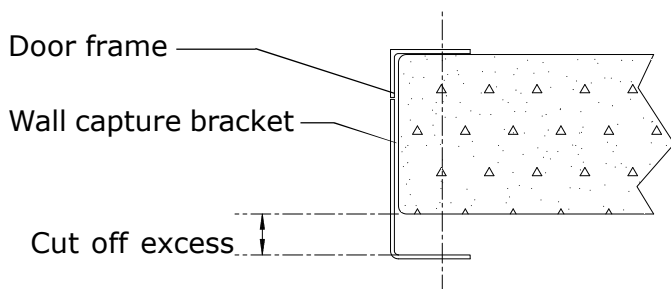

Figure 21

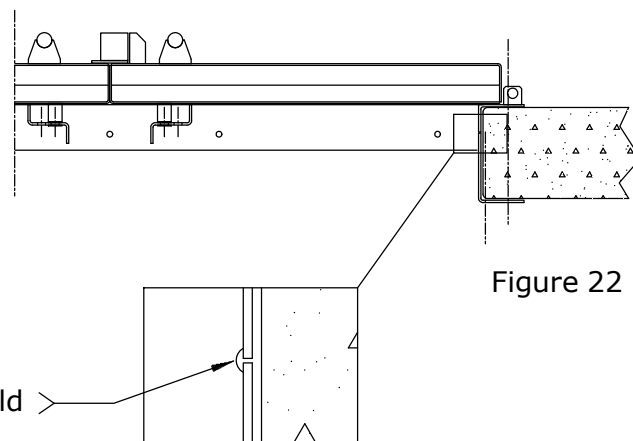

Figure 22

Sealing the inside door frame lip

After the cement grout is dry and the door frame anchor bolts have been tightened apply a liberal amount of silicon caulking between the inner door frame lip and the sill area.

Filling the door cavity with concrete

The door envelope is ready for pouring the concrete. It must be secured in the closed position before filling and while the concrete is curing — the door must not be opened for at least 4 days while the concrete cures.

If there is no other entrance to the shelter, the door may be secured in the shut position without closing the cam latches — but it must not sag outward after the door leaves are filled with concrete.

The amount of concrete required will depend on the door size ordered.

The formula for calculating the needed fill amount of concrete in cubic feet is the height of the door in inches times the width of the door in inches times the thickness of the door in inches divided by 1,728 (one cubic foot in inches).

Concrete wedge anchor - technical information

The ThunderStud® wedge anchor consists of two pieces, permanently pre-assembled into a single unit. The carbon steel rod is threaded for a portion of its length. The extreme end of the threaded portion is rounded to protect the threads from damage while the anchor is being driven into the hole drilled in the concrete. The other end of the rod has a necked down diameter, which runs for a short distance, at the end of which it tapers outwardly to the full diameter of the rod. A precision formed universal clip made of carbon steel is permanently assembled around the necked down diameter to complete the anchor. Each package contains the correct number of nuts and washers.

Concrete Wedge Anchor - Approvals

Listed by Underwriters Laboratories (UL), International Conference of Building Officials (ICBO) carbon steel only, Board of Standards and Appeals (BSA), City of L.A. Meets or exceeds U.S. Government G.S.A. Specifications FF-S-325 Group 11, Type 4, Class

Concrete Wedge Anchor - Applications

Medium to heavy duty into concrete.

Concrete Wedge Anchor - Installation

(1) Drill hole into concrete with a carbide tipped masonry drill bit conforming to ANSI B94, 12-77, the same size as the ThunderStud® wedge anchor. If the fixture being fastened is in place and being used as a template to locate the ThunderStud® anchor, the mounting hole in the fixture should afford clearance for the universal wedge clip on the stud. (2) Clean hole, place the ThunderStud® wedge anchor through the hole in the fixture or directly into the concrete and hammer it in to the drilled hole until the threads are below the surface of the fixture/concrete. (3) Turn the nut by hand until the unit is snugged up. Tighten the nut with a wrench, approximately three or four full turns, to complete the fastening.

Concrete Wedge Anchor - Anchor Length

Minimum embedment, plus fixture, plus nut and washer. The ThunderStud® wedge anchor requires no maximum hole depth. The depth of the hole in the concrete should be the length of the wedge anchor minus the thickness of the material being fastened. This will result in some extra depth to accommodate a minor amount of concrete cutting which may not be able to be cleaned out of hole.